



optima



Great performances: perfectly cleaned surfaces also in heavy dirt conditions. Optima is a ride on scrubbing machine with a robust design, suitable for working in different environments, both commercial and industrial, up to 15,000 sq. m. ensuring excellent performances, even for the deep cleaning of various hard floors such as warehouses, logistic centers or finer surfaces such as in shopping malls. Comfort and complete control over the machine ensured by the operator position and easy controls, enhance the results during the operations. The big tanks capacity increases working autonomy while quiet operations allow to perform also in daytime without disturbing the people around: such features guarantee great efficiency and productivity.

Simple and comfortable: to help the operator to get the best results.

The driver's seat is comfortable, accessible from both sides, it offers a complete visibility of the whole working area and favours the control over all functions without distractions. The new instrument panel has been designed to make its use easier. Scrubbing versions (Optima 85/100 B) are equipped with a button for the automatic brush uncoupling.



With the versions equipped with CDS dosing system it is possible to be very precise in adjusting water quantity and detergent percentage and to save the settings inside the program selector to use them again automatically for the next cleaning operation.



It is possible to choose 3 different working speeds and brush pressure levels to adjust the machine to any conditions.



With the working program selector the operator can choose to set the machine operation for: transfer, drying, scrubbing and drying simultaneously or only scrubbing.



MODELS

OPTIMA 85 B
Scrubbing version
with two disc brushes

OPTIMA 100 B
Scrubbing version
with two disc brushes

OPTIMA 90 S
Sweeping version

With resource-saving and consumption-monitoring technologies

ECO DEVICE

Only one button to reduce energy consumption and noise level. It is an ideal working setting for maintenance cleaning and to use the machine in sensitive or frequented environments.



CDS - COMAC DOSING SYSTEM

Separate water and detergent management

Optima can be equipped upon request with CDS (Comac Dosing System) for the separate management of water and detergent, that allows to increase or reduce their flow, according to the type of dirt to clean, thus avoiding wastes. It reduces cleaning solution consumption by up to 50%.

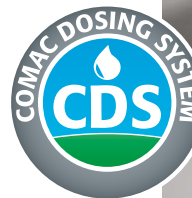

CFC - COMAC FLEET CARE

Optima can be arranged with the equipment needed for fleet management through Comac Fleet Care (CFC). Such system allows the remote control of machines status: if, when and where each machine is operating or if maintenance is needed, to let you promptly intervene avoiding machine downtimes and unexpected costs for extraordinary maintenance.



PM - PRESSURE MONITORING

System for monitoring the pressure on the brushes

Monitors the power dispensed by the brush motors in order to guarantee maximum effectiveness on any type of flooring.



REFERENCE SECTORS



Industrial



Cleaning companies



Health



Public



Horeca



Sports



Automotive



Large-Scale Retail Trade



Transport



Logistic

Safe and silent: it preserves the health of the user and of the people around

FURTHER FEATURES GUARANTEEING THE MAXIMUM WORKING SAFETY:

- antiskid and non-marking motor wheel and rear wheels
- led headlights with different light levels
- reverse warning device
- horn
- possibility to request the blinking light kit, available as optional
- emergency button placed on the instrument panel that immediately stops the machine and all the active functions
- the front-rear bumper, available as optional
- back headlights



Optima is equipped with an hydraulic brake that works on the rear wheels, thus increasing safety and comfort . The electro brake mounted on the front motor-wheel works as an emergency or parking brake.

TO INCREASE PERFORMANCES SOME OPTIONAL ACCESSORIES ARE AVAILABLE:

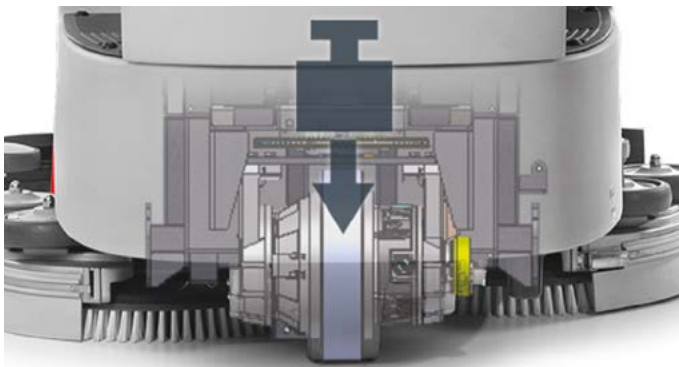

To obtain the maximum effectiveness, Optima can be equipped with the Ramps Kit which allows to increase the grip of the front wheel, improving the performance while going up on possible ramps. Thanks to the extra weight the load will be distributed in a way that avoids any slip of the drive wheel.



The vacuum motors are isolated inside a double wall chamber, that reduces the noise level to work silently, preserving the operator's health.

The tools that will save your time



The length of the hose for solution tank filling allows to directly and comfortably reach a water tap. As optional a fast fill system with float is also available to reduce downtimes.

The brushes of the scrubbing-sweeping version Optima 90 S can be replaced in few seconds without any tools.

PROPER DAILY MAINTENANCE KEEPS CLEANING PERFORMANCES CONSTANT OVER TIME

Yellow color-code identifies the parts involved in daily maintenance. At the end of the shift the operator can easily and quickly find what parts have to be sanitized, without wasting time

DAILY MAINTENANCE



The hoses for the tanks emptying are in the back of the machine, in a comfortable and visible position. The position of the hose is designed to avoid accidental water leak due to the water pressure. The large diameter makes the emptying faster and handier.



The solution filter is positioned in a very accessible place and the vacuum floats/filters can be quickly removed, making the cleaning of the machine at the end of the operation really fast and easy.

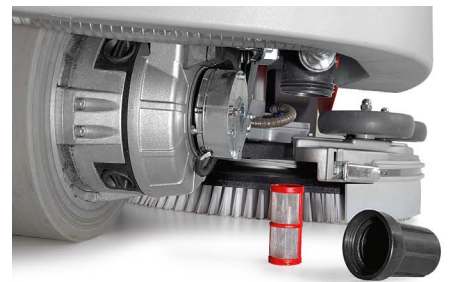

CERTIFICATIONS



STANDARD EQUIPMENTS	Optima 85	Optima 100	Optima 90 S
Comfort			
Hour meter	•	•	•
Eco Mode	•	•	•
Electronic control panel with diagnostics	•	•	•
Squeegee/brush base lift	Automatic	Automatic	Automatic
Automatic brush uncoupling	•	•	•
Speed adjustment	•	•	•
Squeegee rubber blades usable on 4 sides	•	•	•
Color-coded parts for easy maintenance	•	•	•
Flexible filling hose with drop-stop	•	•	•
Water level indicator	•	•	•
Tool-holder hook	•	•	•
Safety			
Emergency stop	•	•	•
Hydraulic working brake	•	•	•
Automatic parking brake	•	•	•
Antiskid wheels	•	•	•
Dead man's switch	•	•	•
Reverse warning device	•	•	•
Horn	•	•	•
LED front headlights with two different light levels	•	•	•
Back headlights	•	•	•

ACCESSORIES	Optima 85	Optima 100	Optima 90 S
CDS (Comac Dosing System)	•	•	•
Ramps kit	•	•	•
Blinking light	•	•	•
Bumper	•	•	•
Fast filling system	•	•	•

OPTIONAL	Optima 85	Optima 100	Optima 90 S
CFC (Comac Fleet Care)	•	•	•
Vacuum dual power extreme	•	•	•

TECHNICAL DESCRIPTION		Optima 85	Optima 100	Optima 90 S
Solution tank	l/gal	160/42,2	160/42,2	160/42,2
Recovery tank	l/gal	140/36,98	140/36,98	140/36,98
Voltage and nominal power	V/W	24/2840	24/2840	24/3340
Working width	mm/inch	850/33,46	1010/40	865/34,2
Squeegee width	mm/inch	1120/44,3	1120/44,3	1120/44,3
Working capacity up to	sq.m/h/sqft/h	6800/73194,52	8080/86972,31	6920/74486,19
Disc brush	(n.) mm/inch	(2) 430/17	(2) 510/20	-
Cylindrical brushes	(n.) mm	-	-	(2) 150-210x865/ 5,9-8,3x33,66
Debris hopper capacity	l/gal	-	-	10/2,64
Brush pressure	Kg/lbs	85/187,4	85/187,4	50/110,2
Brush motor	V/W	(2) 24/500	(2) 24/500	(1) 24/1500
Brush revolution	rpm	160	160	810-590
Vacuum motor	V/W	(2) 24/420	(2) 24/420	(2) 24/420
Suction vacuum	mbar	190	190	190
Acoustic level	db (A)	<70	<70	<70
Traction	-	aut./front.	aut./front.	aut./front.
Traction motor	V/W	24/1000	24/1000	24/1000
Forward speed	Km/h/mpH	0÷8/4,97	0÷8/4,97	0÷8/4,97
Turning diameter	mm/inch	2530/99,6	2530/99,6	2530/99,6
Battery compartment dimensions (Lxhxw)	mm/inch	630x470x430/25x21x17	630x470x430/25x21x17	630x470x430/25x21x17
Max gradient at full load	%	10	10	10
Batteries (q.tà)	V/Ah C5	1 BOX - 24/320	1 BOX - 24/320	1 BOX - 24/320
Batteries weight	Kg/lbs	225/497	225/497	225/497
Detergent tank capacity (CDS)	l/gal	5/1,3	5/1,3	5/1,3
Machine dimensions (Lxhxw)	mm/inch	1796x1245x900/ 70,71x49,20x35,43	1796x1245x1055/ 70,71x49,20x41,54	1796x1245x1005 70,71x49,20x39,57
Machine weight (without batteries)	Kg/lbs	340/749,57	340/749,57	363/800,28



COMAC S.p.A. Via Maestri del Lavoro, 13 - 37059 Santa Maria di Zevio - Verona - ITALY
Tel. 045 8774222 - Fax 045 8750303 - www.comac.it - com@comac.it

Comac S.p.A. org. cert. ISO 9001:2015, ISO 14001:2015, ISO 45001:2018, SA 8000:2014

